

HD CCTV Total Solution

IR Dome Camera User Manual



The product image shown above may differ from the actual product.
Please use this camera with a DVR which supports HD video recording.
Please read the instructions thoroughly before using the product.

d207b_d_e_V0.9

757Z

HD CCTV Total Solution

IR Dome Camera User Manual



The product image shown above may differ from the actual product.
Please use this camera with a DVR which supports HD video recording.
Please read the instructions thoroughly before using the product.

d207b_d_e_V0.9

IMPORTANT SAFEGUARD



CAUTION
RISK OF ELECTRIC SHOCK



CAUTION:

To reduce the risk of electric shock, do not expose this apparatus to rain or moisture.

Only operate this apparatus from the type of power source indicated on the label.

The company shall not be liable for any damages arising out of any improper use, even if we have been advised of the possibility of such damages.



The lightning flash with arrowhead symbol, within an equilateral triangle, is intended to alert the user to the presence of uninsulated "dangerous voltage" within the product's enclosure that may be of sufficient magnitude to constitute a risk of electric shock to persons.



This exclamation point within an equilateral triangle is intended to alert the user to the presence of important operating and maintenance (servicing) instructions in the literature accompanying the appliance.



All lead-free products offered by the company comply with the requirements of the European law on the Restriction of Hazardous Substances (RoHS) directive, which means our manufacture processes and products are strictly "lead-free" and without the hazardous substances cited in the directive.



The crossed-out wheeled bin mark symbolizes that within the European Union the product must be collected separately at the product end-of-life. This applies to your product and any peripherals marked with this symbol. Do not dispose of these products as unsorted municipal waste. Contact your local dealer for procedures for recycling this equipment.



CE Mark

This apparatus is manufactured to comply with the radio interference.

The company does not warrant that this manual will be uninterrupted or error-free. We reserve the right to revise or remove any content in this manual at any time.

IMPORTANT SAFEGUARD



CAUTION
RISK OF ELECTRIC SHOCK



CAUTION:

To reduce the risk of electric shock, do not expose this apparatus to rain or moisture.

Only operate this apparatus from the type of power source indicated on the label.

The company shall not be liable for any damages arising out of any improper use, even if we have been advised of the possibility of such damages.



The lightning flash with arrowhead symbol, within an equilateral triangle, is intended to alert the user to the presence of uninsulated "dangerous voltage" within the product's enclosure that may be of sufficient magnitude to constitute a risk of electric shock to persons.



This exclamation point within an equilateral triangle is intended to alert the user to the presence of important operating and maintenance (servicing) instructions in the literature accompanying the appliance.



All lead-free products offered by the company comply with the requirements of the European law on the Restriction of Hazardous Substances (RoHS) directive, which means our manufacture processes and products are strictly "lead-free" and without the hazardous substances cited in the directive.



The crossed-out wheeled bin mark symbolizes that within the European Union the product must be collected separately at the product end-of-life. This applies to your product and any peripherals marked with this symbol. Do not dispose of these products as unsorted municipal waste. Contact your local dealer for procedures for recycling this equipment.



CE Mark

This apparatus is manufactured to comply with the radio interference.

The company does not warrant that this manual will be uninterrupted or error-free. We reserve the right to revise or remove any content in this manual at any time.

TABLE OF CONTENTS

FEATURES	1
PACKAGE CONTENT	1
DIMENSIONS*	2
SPECIFICATIONS*	3
INSTALLATION	4
CONNECTION	7
CAMERA PARAMETERS	8

TABLE OF CONTENTS

FEATURES	1
PACKAGE CONTENT	1
DIMENSIONS*	2
SPECIFICATIONS*	3
INSTALLATION	4
CONNECTION	7
CAMERA PARAMETERS	8

FEATURES

1. 1/2.7" CMOS Sensor
2. 1080P video output
3. f2.8 ~ 12mm vari-focal lens
4. Low light sensitivity of 0.1 Lux / F1.4(Wide)~F2.8(Tele), 0 Lux (IR LED ON)
5. IP66 for weather-proof application
6. Day and night 24-hour surveillance with IR effective distance up to 25 meters
7. Camera parameters adjustable when used with HD CCTV DVR

PACKAGE CONTENT

- IR dome camera
- User manual
- Screws & wall plugs

FEATURES

1. 1/2.7" CMOS Sensor
2. 1080P video output
3. f2.8 ~ 12mm vari-focal lens
4. Low light sensitivity of 0.1 Lux / F1.4(Wide)~F2.8(Tele), 0 Lux (IR LED ON)
5. IP66 for weather-proof application
6. Day and night 24-hour surveillance with IR effective distance up to 25 meters
7. Camera parameters adjustable when used with HD CCTV DVR

PACKAGE CONTENT

- IR dome camera
- User manual
- Screws & wall plugs

DIMENSIONS*

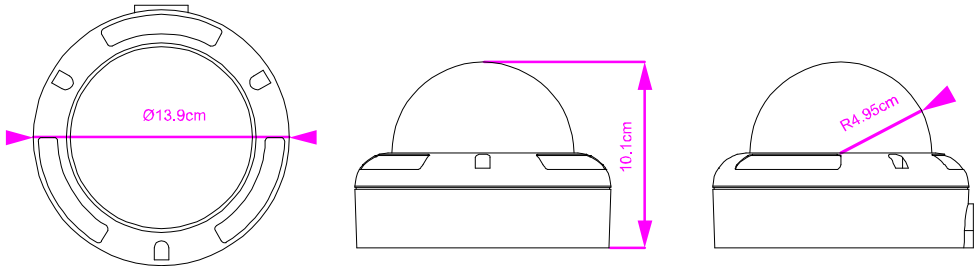

*Dimensional Tolerance: $\pm 5\text{mm}$

2

DIMENSIONS*

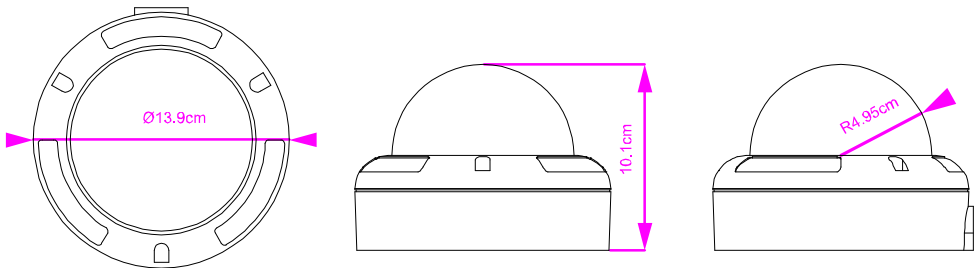

*Dimensional Tolerance: $\pm 5\text{mm}$

2

SPECIFICATIONS*

Pick-up Element	1/ 2.7" CMOS image sensor
Number of Pixels	1930(H) x 1088(V)
Video Frame Rate	1080P@30fps / 1080P@25fps
Min. Illumination	0.1 Lux / F1.4(Wide)~F2.8(Tele), 0 Lux (IR LED ON)
S/N Ratio	More than 48dB (AGC OFF)
Shutter Speed	1/30 (1/25) sec ~ 1/720000 (1/600000) sec
Lens	f2.8 ~ 12mm / F1.4 ~ F2.8
Lens Angle	Wide: 104° (Horizontal) / 56° (Vertical) / 124° (Diagonal) Tele: 35° (Horizontal) / 20° (Vertical) / 40° (Diagonal)
IR LED	6 units
IR Effective Distance	Up to 25 meters
IR Shift	YES
Day & Night Mode	YES
IRIS Mode	AES
White Balance	AUTO / USER / PUSH / 8000K / 6000K / 4200K / 3200K
AGC	Adjustable
Sharpness	Adjustable
Flickerless	50HZ / 60HZ / OFF
BLC	Adjustable
IP Rating	IP66
Operating Temperature	-20°C ~ 40°C
Power Source (±10%)	DC12V / 1A
Current Consumption (±10%)	180mA (LED OFF) / 370mA (LED ON)

* The specifications are subject to change without notice.

SPECIFICATIONS*

Pick-up Element	1/ 2.7" CMOS image sensor
Number of Pixels	1930(H) x 1088(V)
Video Frame Rate	1080P@30fps / 1080P@25fps
Min. Illumination	0.1 Lux / F1.4(Wide)~F2.8(Tele), 0 Lux (IR LED ON)
S/N Ratio	More than 48dB (AGC OFF)
Shutter Speed	1/30 (1/25) sec ~ 1/720000 (1/600000) sec
Lens	f2.8 ~ 12mm / F1.4 ~ F2.8
Lens Angle	Wide: 104° (Horizontal) / 56° (Vertical) / 124° (Diagonal) Tele: 35° (Horizontal) / 20° (Vertical) / 40° (Diagonal)
IR LED	6 units
IR Effective Distance	Up to 25 meters
IR Shift	YES
Day & Night Mode	YES
IRIS Mode	AES
White Balance	AUTO / USER / PUSH / 8000K / 6000K / 4200K / 3200K
AGC	Adjustable
Sharpness	Adjustable
Flickerless	50HZ / 60HZ / OFF
BLC	Adjustable
IP Rating	IP66
Operating Temperature	-20°C ~ 40°C
Power Source (±10%)	DC12V / 1A
Current Consumption (±10%)	180mA (LED OFF) / 370mA (LED ON)

* The specifications are subject to change without notice.

INSTALLATION

Step1: Turn the camera to the back. Remove the appointed two screws. This step is for the convenience of arranging the cable on the ceiling later. (Please refer to *Figure 1*)

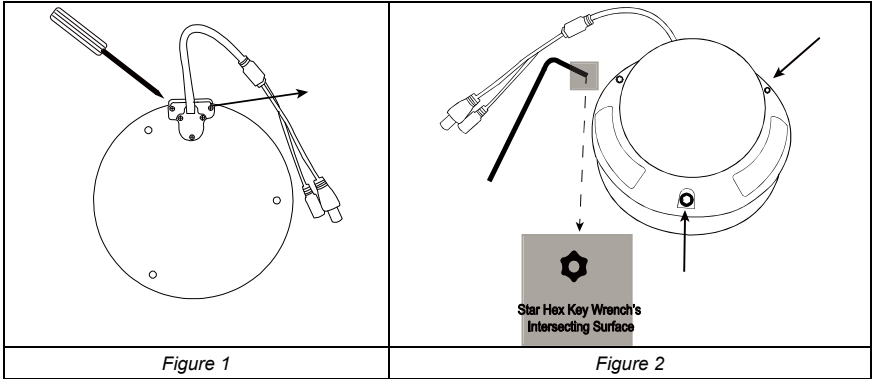

Step2: Remove the three screws on the top of the camera. (Please refer to *Figure 2*)

Note: Please use star hex key wrench in this step.

4

INSTALLATION

Step1: Turn the camera to the back. Remove the appointed two screws. This step is for the convenience of arranging the cable on the ceiling later. (Please refer to *Figure 1*)

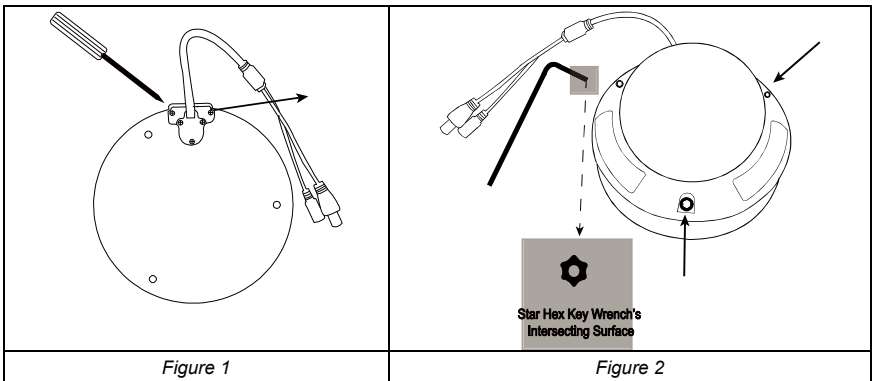

Step2: Remove the three screws on the top of the camera. (Please refer to *Figure 2*)

Note: Please use star hex key wrench in this step.

4

Step3: Open the top of the camera and carefully screw the camera onto the ceiling. Make sure the cables are routed and arranged properly, and then connect it to power supply.

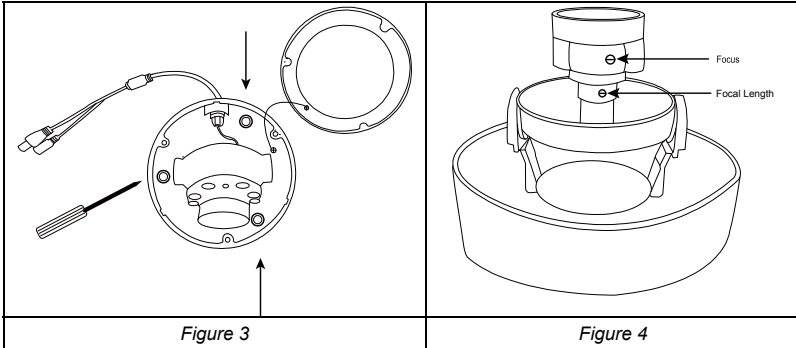

Step4: Now slightly adjust the lens; make sure it faces the target recording area. Loosen the lower screw to adjust the focal length and the upper screw to adjust the focus. (As Figure 4 shows)

5

Step3: Open the top of the camera and carefully screw the camera onto the ceiling. Make sure the cables are routed and arranged properly, and then connect it to power supply.

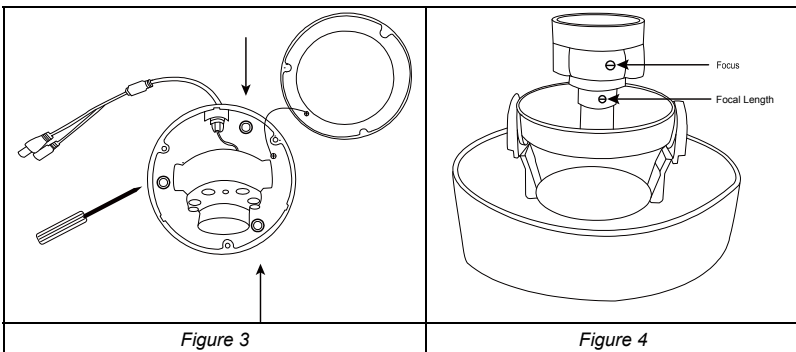

Step4: Now slightly adjust the lens; make sure it faces the target recording area. Loosen the lower screw to adjust the focal length and the upper screw to adjust the focus. (As Figure 4 shows)

5

Step5: Screw the top back to the camera. (Please refer to Figure 5)

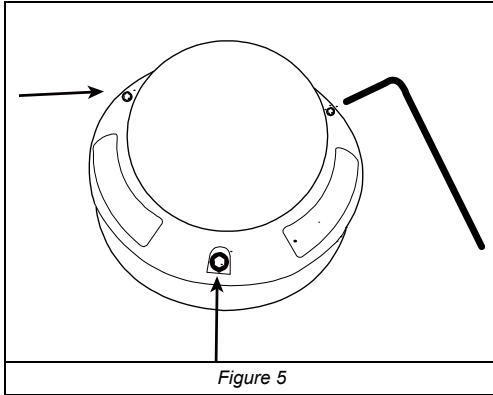

Note: Please use star hex key wrench in this step.

6

Step5: Screw the top back to the camera. (Please refer to *Figure 5*)

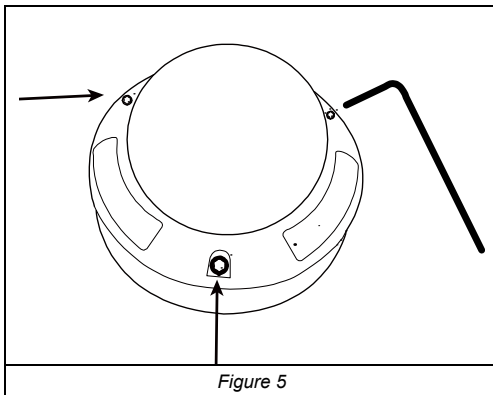

Note: Please use star hex key wrench in this step.

6

CONNECTION

1. DC12V Input Terminal

Connect the power terminal of the camera to a DC 12V regulated power supply.

Note: Please use the correct power adaptor, DC12V (regulated), to operate this unit. The power tolerance of this unit is DC12V \pm 10%. Over maximum DC 12V power input will damage this unit.

1. Video Output Connector (VIDEO OUT)

Connect the camera video output to the video input of a DVR with 75 Ω coaxial cable.

Note: To ensure the camera has sufficient protection against moisture, an extra waterproof measure, such as by using an insulating tape, must be used to cover the power and video connectors after connection.

CONNECTION

1. DC12V Input Terminal

Connect the power terminal of the camera to a DC 12V regulated power supply.

Note: Please use the correct power adaptor, DC12V (regulated), to operate this unit. The power tolerance of this unit is DC12V \pm 10%. Over maximum DC 12V power input will damage this unit.

1. Video Output Connector (VIDEO OUT)

Connect the camera video output to the video input of a DVR with 75 Ω coaxial cable.

Note: To ensure the camera has sufficient protection against moisture, an extra waterproof measure, such as by using an insulating tape, must be used to cover the power and video connectors after connection.

CAMERA PARAMETERS

This camera series has its own configuration menu, and either of the two methods below is available to access the menu based on the camera model you have.

Note: The methods below are available only when the camera is used with our brand's HD CCTV DVR.

■ Method 1

On the DVR live view, click the channel which connects this camera to display in the full screen mode, and select .

■ Method 2

On the DVR live view, right click to show the DVR main menu, and select **ADVANCED CONFIG** → **DCCS**. Then, select the channel which connects this camera, and click **SETUP** to enter the menu of camera parameters.

CAMERA PARAMETERS

This camera series has its own configuration menu, and either of the two methods below is available to access the menu based on the camera model you have.

Note: The methods below are available only when the camera is used with our brand's HD CCTV DVR.

■ Method 1



On the DVR live view, click the channel which connects this camera to display in the full screen mode, and select .

■ Method 2

On the DVR live view, right click to show the DVR main menu, and select **ADVANCED CONFIG** → **DCCS**. Then, select the channel which connects this camera, and click **SETUP** to enter the menu of camera parameters.

ADVANCED CONFIG	
CAMERA	CH1 CH2 CH3 CH4
DETECTION	MENU SETUP
ALERT	
NETWORK	
DISPLAY	
RECORD	
DEVICES	F.W. 1007
DCCS	DEVICE XXXXX
NOTIFY	CONNECTION OK

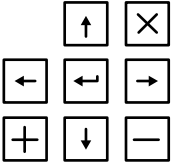

When the camera menu is entered, you'll see the keys on the bottom right corner to move between and change those configurations.

-  Move between selections.
-  Change settings.
-  Call the camera parameters menu or enter the currently-selected item.
- X** Quit the camera parameters mode.



ADVANCED CONFIG	
CAMERA	CH1 CH2 CH3 CH4
DETECTION	MENU SETUP
ALERT	
NETWORK	
DISPLAY	
RECORD	
DEVICES	F.W. 1007
DCCS	DEVICE XXXXX
NOTIFY	CONNECTION OK

When the camera menu is entered, you'll see the keys on the bottom right corner to move between and change those configurations.

-  Move between selections.
-  Change settings.
-  Call the camera parameters menu or enter the currently-selected item.
- X** Quit the camera parameters mode.

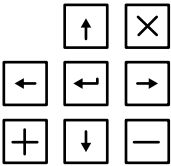

MENU			DESCRIPTION
DAY / NIGHT	MODE	EXT	Use the external light sensor we added in the camera to detect the surrounding light condition and switch to color or B/W mode. If you're not satisfying with the mode switch time, you can go to D TO N / N TO D to manually adjust the sensitivity.
		COLOR	Always keep the day and night mode to day mode.
		B&W	Always keep the day and night mode to night mode.
		AUTO	No function.
	D TO N	1 ~ 63	Set the sensitivity for the day & night mode from day to night. The higher the value, the more sensitivity the mode is switched when the light condition is changed. Note: This function is not available when AUTO and COLOR is selected.

MENU			DESCRIPTION
DAY / NIGHT	MODE	EXT	Use the external light sensor we added in the camera to detect the surrounding light condition and switch to color or B/W mode. If you're not satisfying with the mode switch time, you can go to D TO N / N TO D to manually adjust the sensitivity.
		COLOR	Always keep the day and night mode to day mode.
		B&W	Always keep the day and night mode to night mode.
		AUTO	No function.
	D TO N	1 ~ 63	Set the sensitivity for the day & night mode from day to night. The higher the value, the more sensitivity the mode is switched when the light condition is changed. Note: This function is not available when AUTO and COLOR is selected.

MENU			DESCRIPTION
DAY / NIGHT	N TO D	1 ~ 63	Set the sensitivity for the day & night mode from night to day. The higher the value, the more sensitivity the mode is switched when the light condition is changed. Note: This function is not available when AUTO and COLOR is selected.
	DELAY TIME	1 ~ 60	Set the delay time in second after which the day and night switch is made. This is used for the environment where the light condition may change suddenly and usually last for a short time, for example, the entrance of a parking lot. It may cause the day & night mode switching constantly and damage the camera. With this function, the camera will delay the mode switch at night since the light change is temporary and unnecessary to pay attention.
AWB	MODE	AUTO	Automatically adjust the white balance based on the surrounding environment.
		USER	Manually adjust the white balance parameters. Choose USER , and click ←(ENTER) to enter the USER MODE to modify R / G / B gain parameters.

MENU			DESCRIPTION
DAY / NIGHT	N TO D	1 ~ 63	Set the sensitivity for the day & night mode from night to day. The higher the value, the more sensitivity the mode is switched when the light condition is changed. Note: This function is not available when AUTO and COLOR is selected.
	DELAY TIME	1 ~ 60	Set the delay time in second after which the day and night switch is made. This is used for the environment where the light condition may change suddenly and usually last for a short time, for example, the entrance of a parking lot. It may cause the day & night mode switching constantly and damage the camera. With this function, the camera will delay the mode switch at night since the light change is temporary and unnecessary to pay attention.
AWB	MODE	AUTO	Automatically adjust the white balance based on the surrounding environment.
		USER	Manually adjust the white balance parameters. Choose USER , and click ←(ENTER) to enter the USER MODE to modify R / G / B gain parameters.

MENU		DESCRIPTION	
AWB	MODE	(PUSH)	It's used for the environment surrounded largely by a particular color, such as blue, causing color confusion. Aim the camera to a white place, and select (PUSH) to memory this white. Then, aim the camera to where it's supposed to face.
		HOLD	It's used to force the camera memorizing the current white balance setting and remain the same even when the environment is changed.
		8000K / 6000K / 4200K / 3200K	Switch to the suitable color temperature based on the current environment to get the right color. 8000K = Shade; 6000K = Cloud; 4200K = White fluorescent; 3200K = Halogen light bulb.
		R-G GAIN	Adjust the red-green value from 1 ~ 255.
		B-G GAIN	Adjust the blue-green value from 1 ~ 255
AE (automatic exposure)	MODE	ESC	Not available for this model.
		HOLD	Not available for this model.
		DC	Not available for this model.

12

MENU		DESCRIPTION	
AWB	MODE	(PUSH)	It's used for the environment surrounded largely by a particular color, such as blue, causing color confusion. Aim the camera to a white place, and select (PUSH) to memory this white. Then, aim the camera to where it's supposed to face.
		HOLD	It's used to force the camera memorizing the current white balance setting and remain the same even when the environment is changed.
		8000K / 6000K / 4200K / 3200K	Switch to the suitable color temperature based on the current environment to get the right color. 8000K = Shade; 6000K = Cloud; 4200K = White fluorescent; 3200K = Halogen light bulb.
		R-G GAIN	Adjust the red-green value from 1 ~ 255.
		B-G GAIN	Adjust the blue-green value from 1 ~ 255
AE (automatic exposure)	MODE	ESC	Not available for this model.
		HOLD	Not available for this model.
		DC	Not available for this model.

12

MENU			DESCRIPTION
AE (automatic exposure)	BRIGHT	0 ~ 255	Set the level of brightness to adjust the brightness of the image. The more the value, the brighter the image.
	SHUTTER	AUTO	Automatically adjust the shutter speed for exposure based on the current environment.
		1/25 1/30 1/50 1/60 1/100 1/120 1/250 1/500 1/1000 1/3000 1/10000	Manually choose the shutter speed you need for exposure.

13

MENU			DESCRIPTION
AE (automatic exposure)	BRIGHT	0 ~ 255	Set the level of brightness to adjust the brightness of the image. The more the value, the brighter the image.
	SHUTTER	AUTO	Automatically adjust the shutter speed for exposure based on the current environment.
		1/25 1/30 1/50 1/60 1/100 1/120 1/250 1/500 1/1000 1/3000 1/10000	Manually choose the shutter speed you need for exposure.

13

MENU			DESCRIPTION
AE (automatic exposure)	FLICKER	OFF / 50HZ / 60HZ	Enable this function to fix the flicker situation.
	AGC	1 ~ 5	Set the level of Auto Gain Control to detect and enhance the image signals when the light condition is poor. The higher the value, the stronger the signals will be enhanced, and the more noise the image will get.
	LSC	ON / OFF	Enable or disable Lens Shading Correction to correct the phenomenon of vignetting when the focal length is short.
SPECIAL	PRIVACY ZONE	AREA SEL.	Select AREA1 or AREA2 to show a predefined area for masking. To move and change the area, please go to SX / EX / SY / EY.
		MASK PAT.	Select the color to mask: black / gray / white. Select OFF to disable area masking.

14

MENU			DESCRIPTION
AE (automatic exposure)	FLICKER	OFF / 50HZ / 60HZ	Enable this function to fix the flicker situation.
	AGC	1 ~ 5	Set the level of Auto Gain Control to detect and enhance the image signals when the light condition is poor. The higher the value, the stronger the signals will be enhanced, and the more noise the image will get.
	LSC	ON / OFF	Enable or disable Lens Shading Correction to correct the phenomenon of vignetting when the focal length is short.
SPECIAL	PRIVACY ZONE	AREA SEL.	Select AREA1 or AREA2 to show a predefined area for masking. To move and change the area, please go to SX / EX / SY / EY.
		MASK PAT.	Select the color to mask: black / gray / white. Select OFF to disable area masking.

14

MENU			DESCRIPTION
SPECIAL	PRIVACY ZONE	SX	Extend / narrow the current area from the left side.
		EX	Extend / narrow the current area from the right side.
		SY	Extend / narrow the current area from the top.
		EY	Extend / narrow the current area from the bottom.
	MOTION*	MOTION	Enable (ON) / disable (OFF) motion detection.
		SENSITI.	Set the sensitivity to trigger motion detection. The higher the value, the more sensitive the camera to trigger motion detection.
		ALARM	Choose the way to show motion detection is triggered: TRACE to frame the area in red which motion trigger occurs on the screen, or ICON to simply show a running man icon for motion trigger occurrences.
		HOLD TIME	Set how long the alarm lasts in second from 1 to 10.



* The function here is for this camera only, and the detection log will be not noted in the DVR.

15



MENU			DESCRIPTION
SPECIAL	PRIVACY ZONE	SX	Extend / narrow the current area from the left side.
		EX	Extend / narrow the current area from the right side.
		SY	Extend / narrow the current area from the top.
		EY	Extend / narrow the current area from the bottom.
	MOTION*	MOTION	Enable (ON) / disable (OFF) motion detection.
		SENSITI.	Set the sensitivity to trigger motion detection. The higher the value, the more sensitive the camera to trigger motion detection.
		ALARM	Choose the way to show motion detection is triggered: TRACE to frame the area in red which motion trigger occurs on the screen, or ICON to simply show a running man icon for motion trigger occurrences.
		HOLD TIME	Set how long the alarm lasts in second from 1 to 10.

* The function here is for this camera only, and the detection log will be not noted in the DVR.

15

MENU			DESCRIPTION
SPECIAL	HLC	HLC	<p>HLC (high light compensation) is used to suppress strong backlight for clearer images. A grey mask will be covered on the source of the strong light. Choose ON and click  (ENTER) to select the areas for this function.</p> <p>The screen will be divided into 16 areas. Move to the area you want, and click  (ENTER) to make X to O.</p>
		MASK VALUE	<p>Set the darkness of the mask.</p> <p>The more the value, the lighter the grey you'll get. The less the value, the darker the grey you'll get.</p>
		THRESHOLD	<p>Set the level of light source which enables masking.</p> <p>The more the value, the stronger the light source will trigger HLC; the less the value, the lighter the light source will trigger HLC.</p>

16

MENU			DESCRIPTION
SPECIAL	HLC	HLC	<p>HLC (high light compensation) is used to suppress strong backlight for clearer images. A grey mask will be covered on the source of the strong light. Choose ON and click  (ENTER) to select the areas for this function.</p> <p>The screen will be divided into 16 areas. Move to the area you want, and click  (ENTER) to make X to O.</p>
		MASK VALUE	<p>Set the darkness of the mask.</p> <p>The more the value, the lighter the grey you'll get. The less the value, the darker the grey you'll get.</p>
		THRESHOLD	<p>Set the level of light source which enables masking.</p> <p>The more the value, the stronger the light source will trigger HLC; the less the value, the lighter the light source will trigger HLC.</p>

16

MENU			DESCRIPTION
EFFECT	COLOR GAIN	0 ~ 255	Set the level of color saturation. The more the value, the more saturated the color will be, but the more noise the image will get.
	COLOR HUE	0 ~ 71	Set the level of hue.
	SHARPNESS	0 ~ 255	Set the level of sharpness to enhance the clarity of image detail by adjusting the aperture and sharpening the edges. The more the value, the sharper the image will be.
	CONTRAST	0 ~ 255	Set the level of contrast. The more the value, the more the contrast level of the image will be.
	BRIGHT OFF.	-128 ~ 127	Set the level to compensate the brightness of the image if needed. The more the value, the brighter the image will be.

17

MENU			DESCRIPTION
EFFECT	COLOR GAIN	0 ~ 255	Set the level of color saturation. The more the value, the more saturated the color will be, but the more noise the image will get.
	COLOR HUE	0 ~ 71	Set the level of hue.
	SHARPNESS	0 ~ 255	Set the level of sharpness to enhance the clarity of image detail by adjusting the aperture and sharpening the edges. The more the value, the sharper the image will be.
	CONTRAST	0 ~ 255	Set the level of contrast. The more the value, the more the contrast level of the image will be.
	BRIGHT OFF.	-128 ~ 127	Set the level to compensate the brightness of the image if needed. The more the value, the brighter the image will be.

17

MENU			DESCRIPTION
EFFECT	MIRROR	OFF / ON	Enable to turn the images horizontally based on your installation situation when necessary.
	FLIP	OFF / ON	Enable to flip the image 180° when necessary.
SYSTEM	CAMERA ID	0 ~ 255	Set the camera ID.
	ID DISP.	OFF / ON	Enable or disable the display of the camera ID.
	NAME DISP.	OFF / ON	This function has no use.
	LANGUAGE	ENG / 中文	Select the language of the menu: English / Simplified Chinese.
	FACTORY INIT	OFF / ON	Enable to restore the camera parameters to factory default values. The camera image will flash once when the reset is done.
EXIT	SAVE & EXIT	--	Save all the changes you've made in each menu and exit.
	EXIT	--	Exit without saving.

18

MENU			DESCRIPTION
EFFECT	MIRROR	OFF / ON	Enable to turn the images horizontally based on your installation situation when necessary.
	FLIP	OFF / ON	Enable to flip the image 180° when necessary.
SYSTEM	CAMERA ID	0 ~ 255	Set the camera ID.
	ID DISP.	OFF / ON	Enable or disable the display of the camera ID.
	NAME DISP.	OFF / ON	This function has no use.
	LANGUAGE	ENG / 中文	Select the language of the menu: English / Simplified Chinese.
	FACTORY INIT	OFF / ON	Enable to restore the camera parameters to factory default values. The camera image will flash once when the reset is done.
EXIT	SAVE & EXIT	--	Save all the changes you've made in each menu and exit.
	EXIT	--	Exit without saving.

18